

Southern Bioproducts and Renewable Energy Conference

How Industry (and Finance) Analyzes Biomass Resource Cost and Availability

Stan Parton – The Parton Group, Inc.

April 15, 2008

Commercialization must first pass the test of **Financing**



- Biomass feedstock is generally the largest component of the Variable Operating Cost
- The long-term success of a project is dependent in part upon a reliable, low-cost supply of feedstock
- For Project Developers –
 - What location will maximize the project returns?
- For Project Financial Backers –
 - Are the material costs in the pro forma realistic?
 - Is there security of supply for the term of the financing?
- **Comprehensive biomass availability and cost studies address these questions**

How Financiers View a Project

- **Rule # 1 – “Don’t lose the invested capital”**

- Rule # 2 –

How Financiers View a Project

- **Rule # 2 – “See Rule #1” – risk averse**

How Financiers View a Project

- **Rule # 2 – “See Rule #1” – risk averse**
- Lenders require a minimum of 1:1 debt coverage ratio based on expected:
 - Revenue - product out-take purchase agreements

How Financiers View a Project

- **Rule # 2 – “See Rule #1” – risk averse**
- Lenders require a minimum of 1:1 debt coverage ratio based on expected:
 - Revenue - product out-take purchase agreements
 - Cost - ‘Worst case’ scenario for feedstock

How Financiers View a Project

- **Rule # 2 – “See Rule #1” – risk averse**
- Lenders require a minimum of 1:1 debt coverage ratio based on expected:
 - Revenue - product out-take purchase agreements
 - Cost - ‘Worst case’ scenario for feedstock
- Lowering the project finance cost is possible by lowering the perceived risk associated with ‘Worst case’ feedstock cost

How Financiers View a Project

- **Rule # 2 – “See Rule #1” – risk averse**
- Lenders require a minimum of 1:1 debt coverage ratio based on expected:
 - Revenue - product out-take purchase agreements
 - Cost - ‘Worst case’ scenario for feedstock
- Lowering the project finance cost is possible by lowering the perceived risk associated with ‘Worst case’ feedstock cost
- Bankable feedstock studies establish a realistic projected cost for materials

Biomass Availability and Cost Studies

- Quantify current market **supply** volumes and changes
- Identify current users / **demand**
- Determine current market **prices**
- Projected demand **changes** for current users
 - Industry trends
 - Company strengths and weaknesses
- Assess the **relative impact** of the proposed project on the primary and secondary supply areas
 - Will the proposed project ‘move the needle’ on the market price and if so by how much? i.e **elasticity**

Forest Products Industry Structure



Traditional Wood Using Markets

- Pulp and paper
 - Ownership structural changes
 - Globalization impacts
 - Domestic market
 - Major but moderately declining market force
 - A competitor for biomass feedstock for steam and power generation
- Panels
 - Output tied to the building industry
 - Current housing slowdown will continue through 2008
 - New capacity being planned and constructed
- Solid wood - lumber
 - Output also tied to the building industry
 - More of a source of biomass feedstock than a competitor
- Mulch
 - A minor player but a regional competitor for bark
- Poles and post

Revenue for Traditional Producers

Output of Specific Forest Manufacturing Sectors

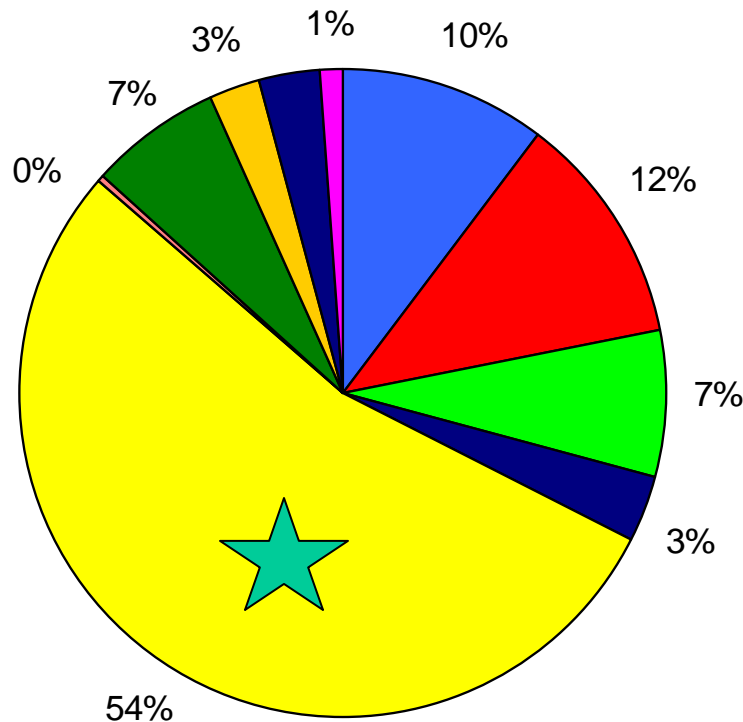

- Logging and nurseries
- Lumber and wood preservation
- Veneer, plywood, and engineered wood
- Manufactured housing and prefab buildings
- Pulp and paper products
- Machines - woodworking and paper
- Wooden furniture and cabinets
- Windows and doors
- Containers, showcases, shelving
- Custom architectural and misc.

Supply infrastructure geared to pulpwood, saw timber
'change is a going to come'

Bioenergy – An Emerging Market

- Emerging but un-quantified long-term impact
- Liquid and gas fuels
 - Biodiesel
 - Bio-syngas
 - Cellulosic ethanol
- Solid fuel - wood pellets
 - Currently an export market to Europe
 - May eventually develop as a domestic market
- Power generation
 - Currently voluntary consumer and RPS driven
 - Activity by both IPPs and regulated utilities

Developed Biomass Feed Stocks

- Primary manufacturing waste (lumber)
 - Sawdust (green)
 - Shavings (dry) (MDF)
 - Bark
- Fuel chips (whole tree chips)
 - May be a limited market and source
 - Supply will develop with demand
 - Location sensitive; prime wood purchasers & wood stock quality
 - Any tree can be used for fuel chips given economic viability
- Secondary manufacturing waste
 - Diverse group: flooring, portable building, pallets, mobile homes, etc
 - Location sensitive
 - May be low cost material (depending on the producer)
- Pulpwood
 - Largest source of material
 - Priced as round wood, cost for conversion to chip required
 - Ceiling price material for most biomass proposed facilities

Pine Round Wood Delivered Prices (Not inflation adjusted)

2nd Quarter 1977 – 2nd Quarter 2007

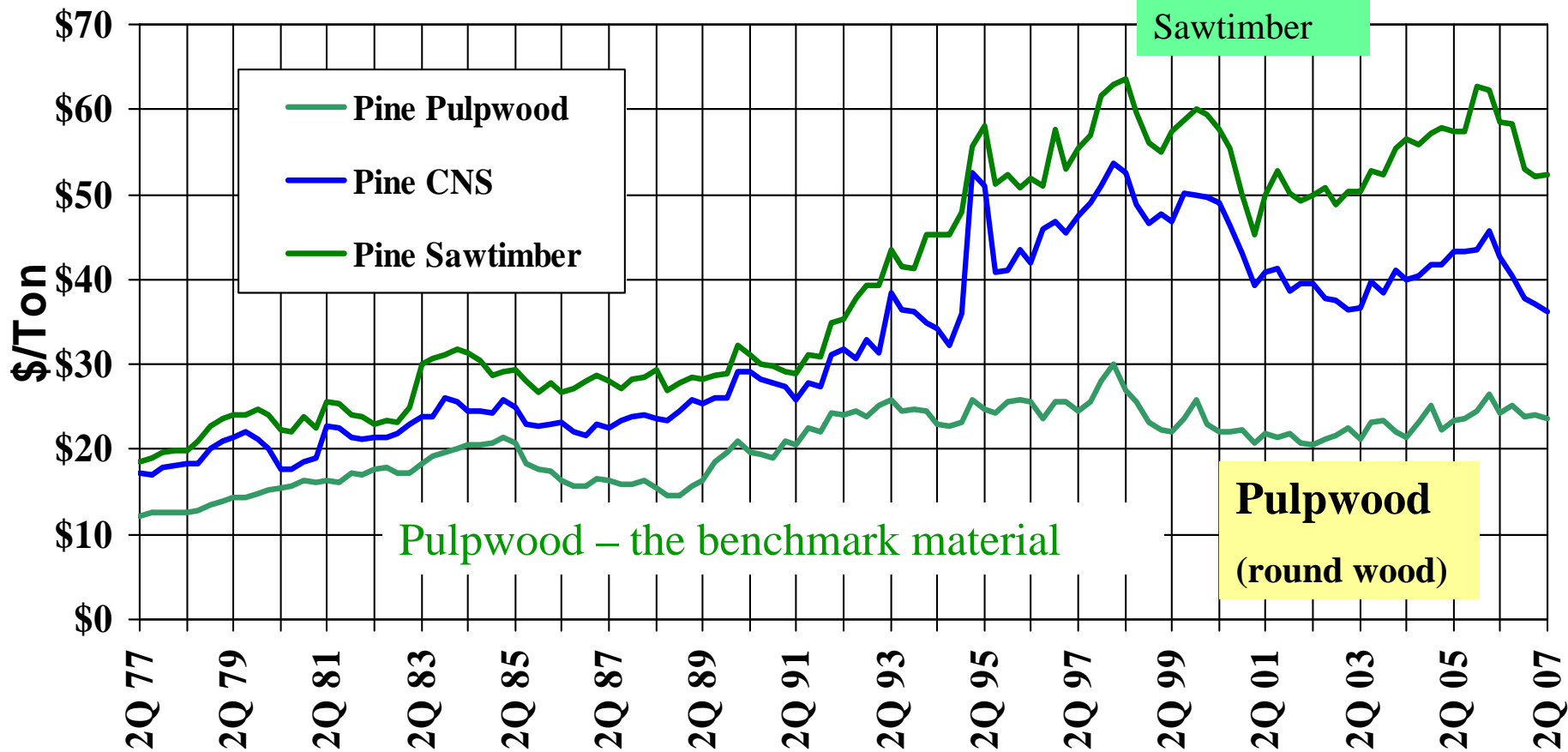

Source: Timber Mart-South

Southeast Average Delivered Pulpwood

Quarterly Average Prices - Constant 1982 \$
2nd Quarter 1977 – 2nd Quarter 2007

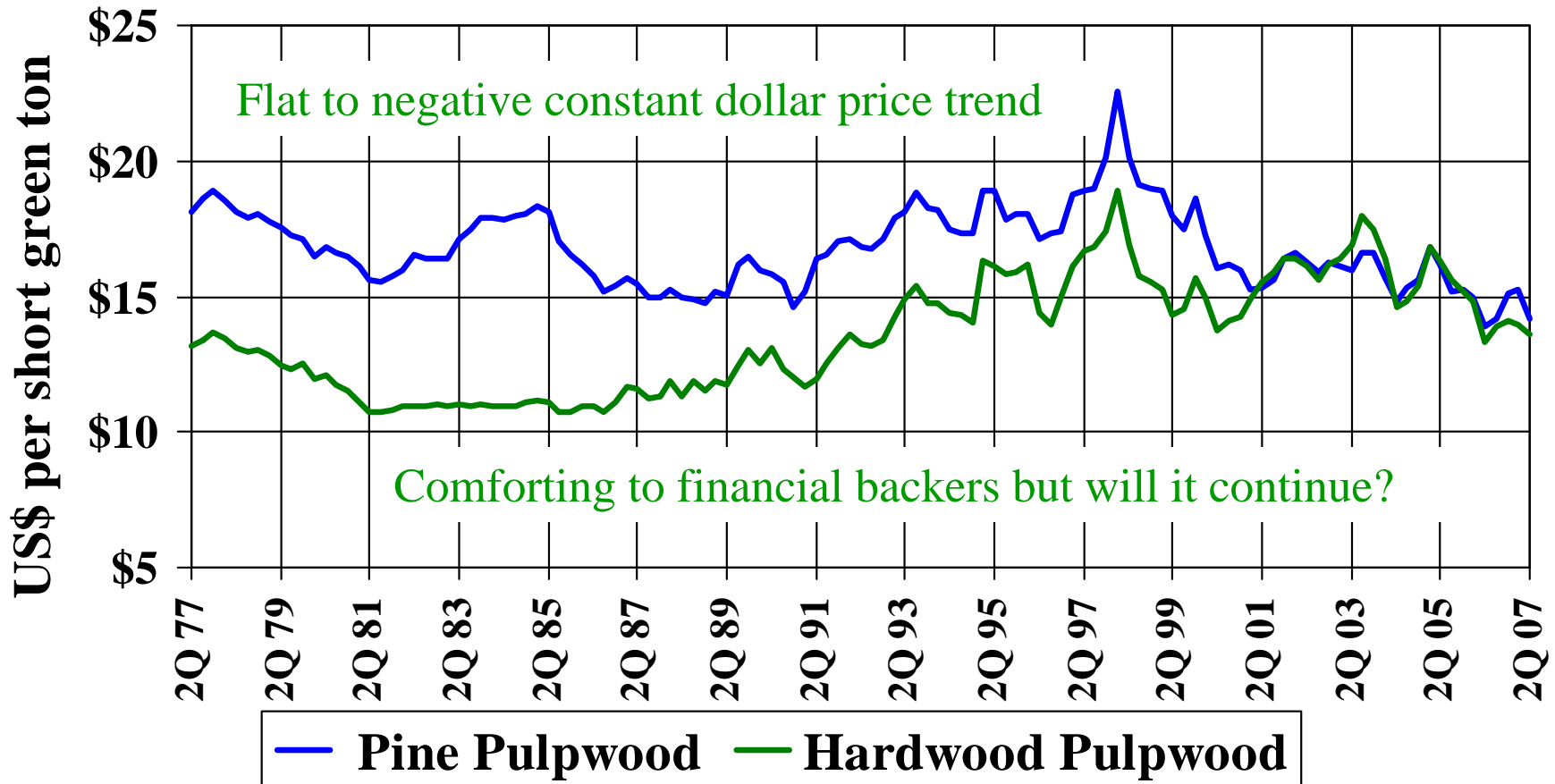

Source: Timber Mart-South & U.S. Census Bureau

SE Pine Fuel Chip vs. Pine Pulpwood Prices

2nd Quarter 1977 – 2nd Quarter 2007

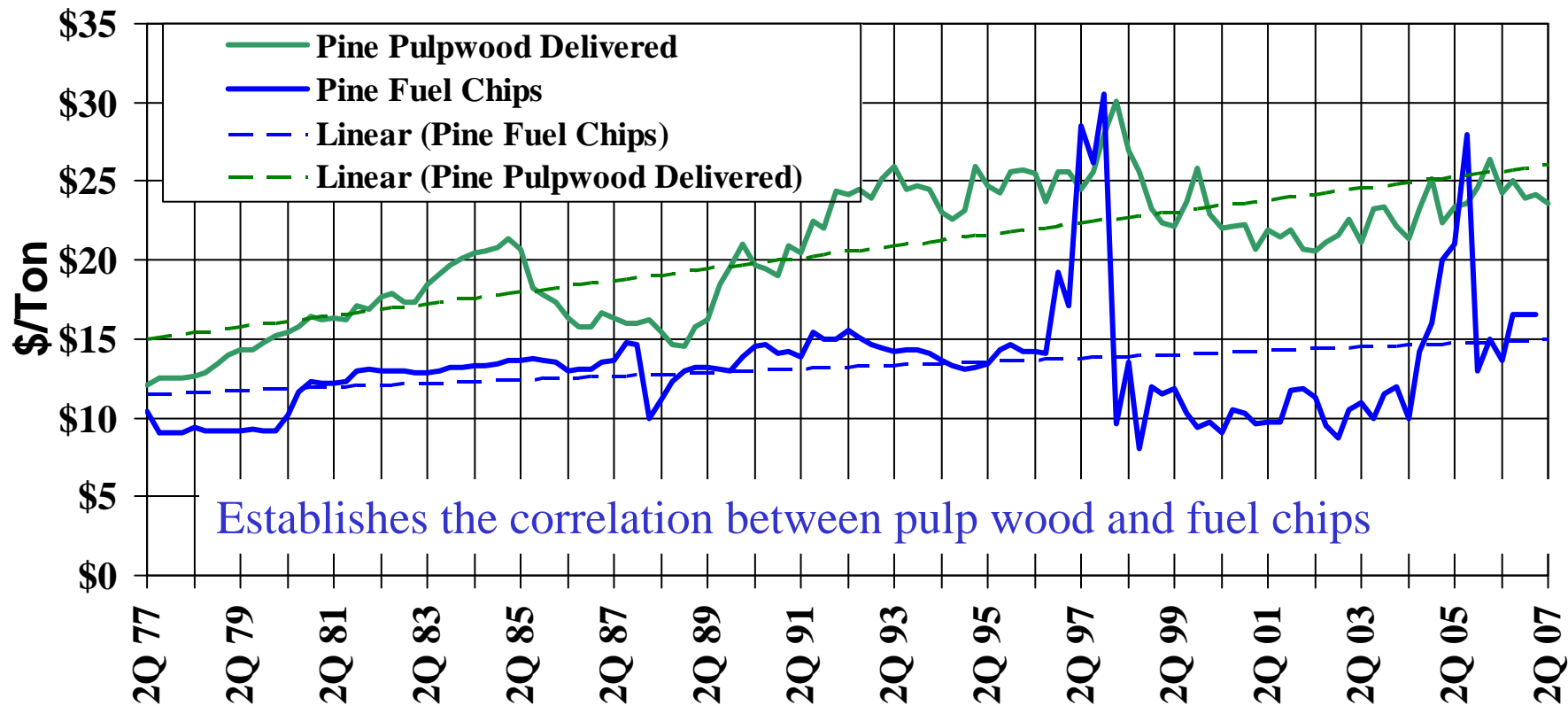

Source: Timber Mart-South

Residue Opportunities for Supply

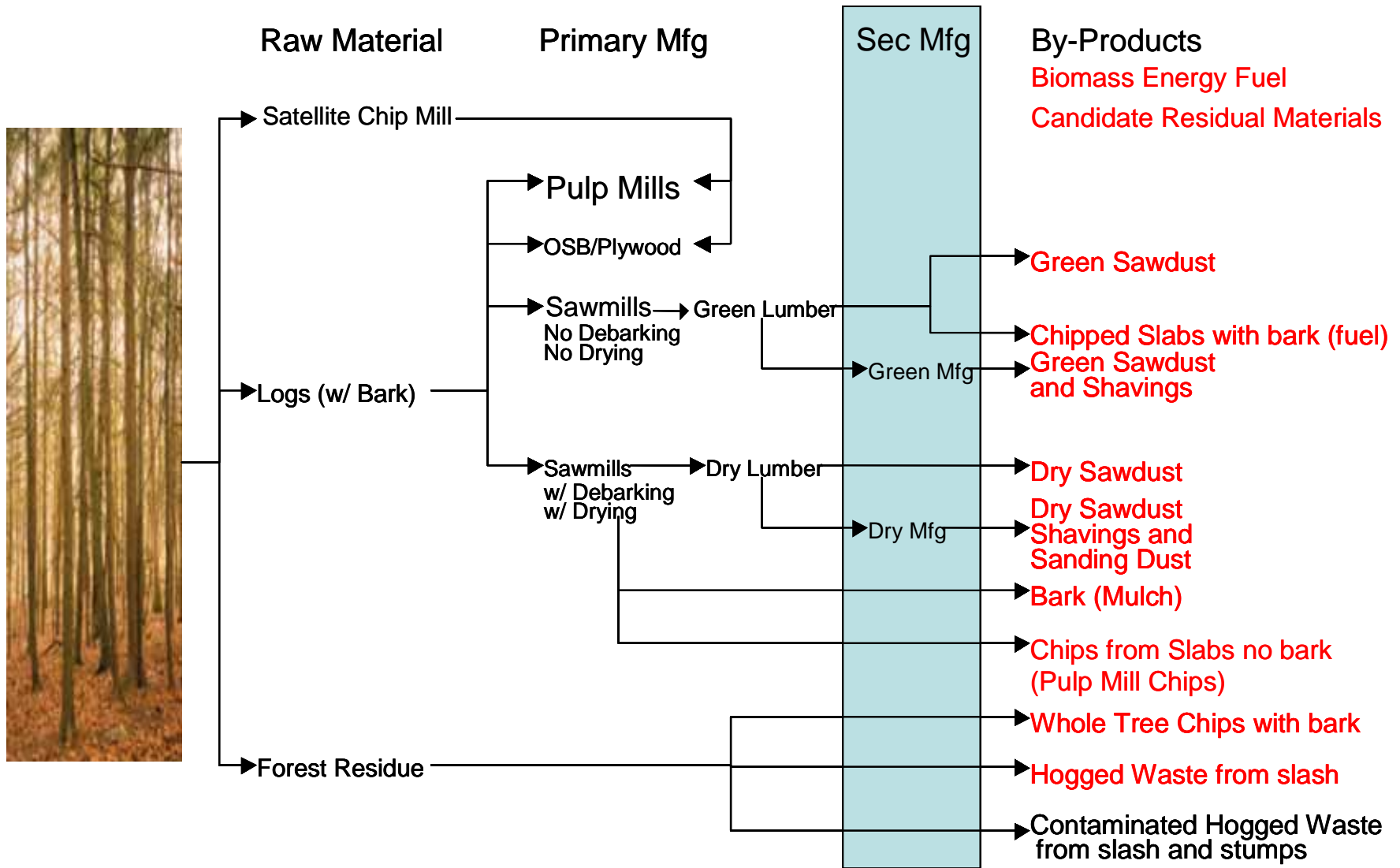

Harvest Residue

- A currently undeveloped or under developed potential feedstock
- Quantities available but sensitive to collection cost
- Investigative work being done on harvest practices and collection cost
- Will likely be an 'add on' business for existing wood harvesters
- Wood harvesters and land owners would like for this new market (and revenue source) to exist, but it must be economically viable
- Variability of material may require special material handling considerations at plant site

Biomass Feedstock Studies

1. Desktop supply and demand **research** for specified materials
2. Phone **survey** of all prospective suppliers
3. Field **visits** to top prospective suppliers
 - Validation of quantities
 - Validation of quality
 - Determination of current transaction cost
 - Determination of current relationship strengths
 - Identification of additional potential suppliers

Sample of Secondary Waste



Hollow Door Manufacturing



Cumulative Delivered Cost Analysis

Supplier	Road Miles To Project	Current Disposal	Monthly Quantity Tons	Purchase Cost \$/Ton	Delivery Cost \$/Ton	Total Cost \$/Ton	Blended Fuel Cost \$/Ton
A	27	Landfilled	75	0.00	3.38	3.38	3.64
B	42	Pay to dispose	320	0.00	3.68	3.68	3.69
C	43	Pay Trans to dispose	1200	0.00	5.02	5.02	4.74
D	80	Landfill	275	0.00	6.09	6.09	4.95
E	91	Given Away	430	0.00	6.37	6.37	5.23
F	55	Pay to dispose	320	0.00	6.88	6.88	5.44
G	110	Pay to dispose	87	0.00	7.70	7.70	5.51
H	69	Landfilled	90	0.00	8.63	8.63	5.62
I	90	Given Away	68	0.00	9.26	9.26	5.71
J	84	Given Away	360	0.00	9.80	9.80	6.18
K	80	Sold	75	6.52	6.09	12.61	6.34
L	53	Sold	170	8.00	4.64	12.64	6.66
M	132	Given Away	68	0.00	13.59	13.59	6.80
N	23	Sold	190	12.20	1.61	13.81	7.16
O	45	Sold	300	12.93	5.43	18.36	8.02
P	65	Sold	225	12.00	8.13	20.13	8.68
Q	96	Sold	180	11.00	11.20	22.20	9.24
R	69	Sold (?)	100	15.00	8.63	23.63	9.57
S	96	Sold	180	15.00	11.20	26.20	10.22
T	27	Sold as fuel	120	27.05	2.15	29.19	10.70
U	107	Sold	750	26.00	7.49	33.49	13.81

Greater Consumption = Greater Price

Theoretical Lowest Fuel Cost

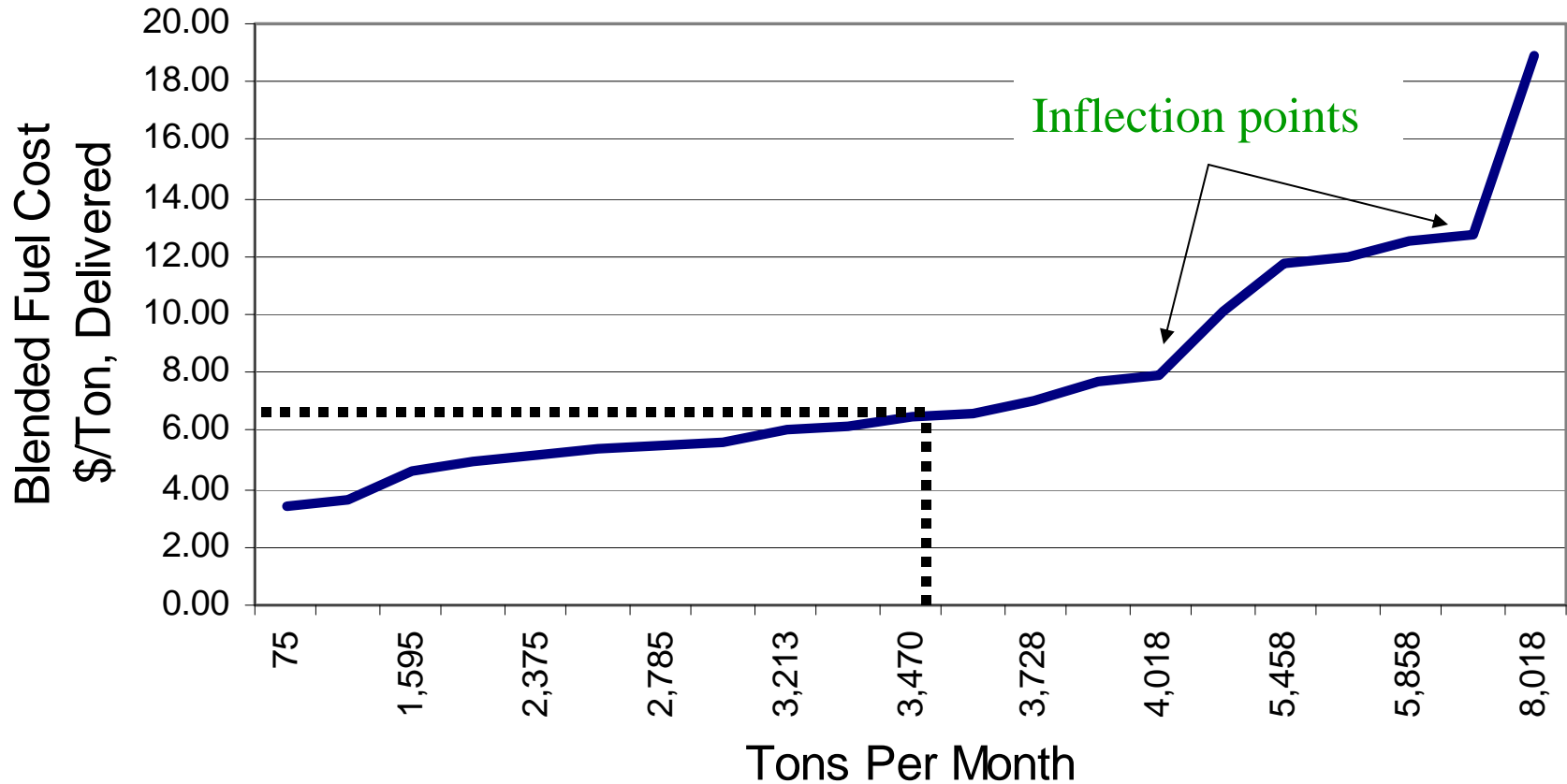

Summary

- Biomass feedstock represents the greatest component of the Variable Operating Cost for a facility.
- The financial success and securing of the lowest cost financing for projects is tied to properly understanding the current and projected availability and cost of suitable feedstock materials.
- Comprehensive biomass availability and cost studies are therefore a requirement both for developers and financiers of projects.

The Parton Group, Inc

www.thepartongroup.com

Stan Parton

770-925-8349

stanparton@thepartongroup.com

